

Notes:

100 mm TV – woofer,
paper cone,
paper dustcap,
rubber edge,
rubber gasket,
shielded with double
magnet and metal cap,
terminals:

“+” 4.8 x 0.8mm
“-” 2.8 x 0.8mm

impedance:	8 Ω
nom. power:	30 watts
SPL 1W/1m:	87 dB
fs:	98 Hz
Re:	7.4 Ω
Le:	0.4 mH
Qms:	2.0
Qes:	0.85
Qts:	0.6
VAS :	3 l
Mms :	3.7 g
Rms :	1.2 kg/s
Cms:	0.7 mm/N
B*I:	4.2 Tm
Sd:	54 cm ²
Xmax:	+/- 2 mm
weight:	0.6 kg
magnet:	8 oz
voice coil Ø:	25 mm

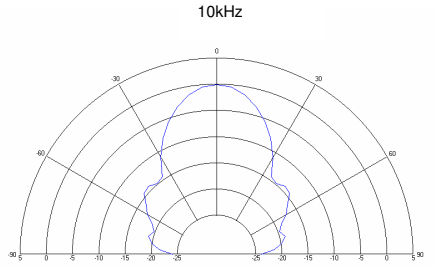
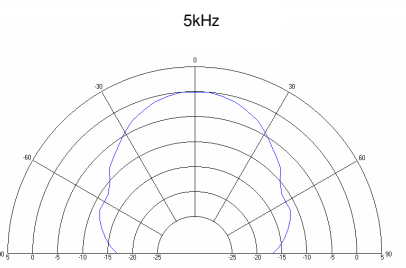
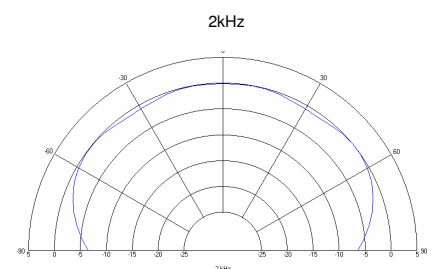
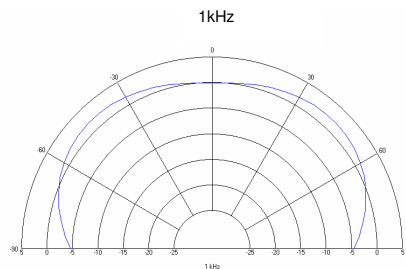
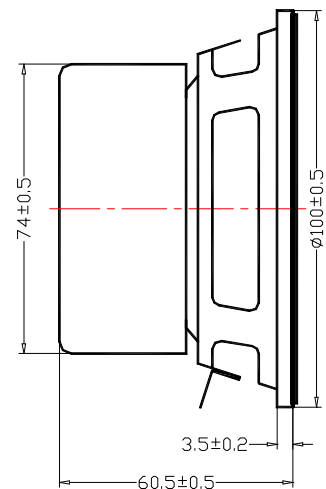
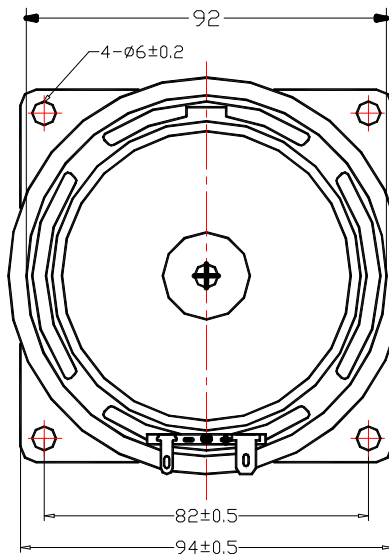

TECHNICAL DATA ARE MEASURED WITH ATB – EQUIPMENT ACCORDING EN – 60268 –5.

FOR PRODUCT IMPROVEMENT HKM RESERVES ALTERATIONS IN SPECIFICATIONS AND DESIGN WITHOUT FURTHER ANNOUNCEMENT

FOR TOLERANCES OF TECHNICAL DATA REFER TO HKM 'S MANUAL OF TECHNICAL DATA

FOR INFORMATION CONTACT: TEL.: +49 9073 / 9585 0, FAX.: +49 9073 / 9585 55, E-MAIL: INFO@HKM-GROUP.DE